

LRB01-LRB01S -LRB04 - LRB04A and LRB06

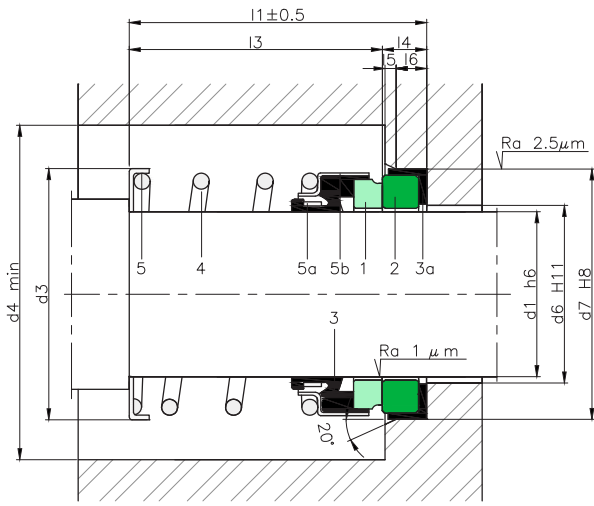

COMPONENTS:

- 1 Rotating contact surface
- 2 Stationary contact surface
- 3 Bellows
- 3a Elastomeric cup
- 4 Spring
- 5 Ring
- 5a Drive ring
- 5b Metal frame



SECTORS:



CHARACTERISTICS:

- Unbalanced.
- Not dependent on the rotation direction.
- Single cylindrical spring.

OPERATING LIMITS:

$d_i = 9.52 \div 101.60 \text{ mm}$ $p = 10 \text{ kg/cm}^2$
 $v = 10 \text{ m/s}$ $t = -15 \div +200^\circ\text{C} (*)$

(*) The temperature resistance depends on the material of the secondary seals used.

The operating limits are defined by the PV factor which is determined for the sealing system characteristics and those of the application.

DESCRIPTION:

Mechanical seal with a simple design for general use. Type LRB04/ LRB04A are standardised models in accordance with EN 12756 (KU).

DIMENSIONS CHART LRB01

Dimensions in inches

Shaft (")	Rotary part			Stationary part						Total length l ₁
	mm	d ₃	d ₄	l ₃	d ₆	d ₇	l ₄	l ₅	l ₆	
3/8	9.52	23.80	28.80	22.20	15.90	22.22	6.3	1.3	5.1	28.50
1/2	12.70	23.80	28.80	20.60	19.05	25.40	8.0	1.3	5.1	28.60
5/8	15.88	26.50	31.50	22.20	22.20	31.75	10.3	1.3	7.5	32.50
3/4	19.05	30.50	35.50	22.20	25.40	34.93	10.3	1.3	7.5	32.50
7/8	22.20	34.00	39.50	24.00	28.60	38.10	10.3	1.3	7.5	34.30
1	25.40	40.00	45.00	25.40	31.80	41.28	11.0	1.3	8.3	36.40
1 1/8	28.60	44.50	49.50	27.00	35.70	44.45	11.0	1.3	8.3	38.00
1 1/4	31.75	46.50	52.00	27.00	38.90	47.66	11.0	1.3	8.3	38.00
1 3/8	34.92	51.50	56.50	28.50	42.10	50.80	11.0	1.3	8.3	39.50
1 1/2	38.10	54.00	60.00	28.50	45.20	54.00	11.0	1.3	8.3	39.50
1 5/8	41.27	58.00	63.00	35.00	48.80	60.30	12.7	1.3	9.8	47.70
1 3/4	44.45	61.50	66.50	35.00	51.60	63.50	12.7	1.3	9.8	47.70
1 7/8	47.62	65.50	70.50	38.00	54.80	66.65	12.7	1.3	9.8	50.70
2	50.80	70.50	75.50	38.00	58.00	69.85	12.7	1.3	9.8	50.70
2 1/8	53.97	75.00	80.00	43.00	62.00	76.20	14.3	1.3	11.4	57.30
2 1/4	57.15	79.00	84.00	43.00	65.00	79.40	14.3	1.3	11.4	57.30
2 3/8	60.32	82.00	87.00	46.00	68.00	82.55	14.3	1.3	11.4	60.30
2 1/2	63.50	87.00	92.00	46.00	71.20	85.70	14.3	1.3	11.4	60.30
2 5/8	66.68	88.00	96.50	49.20	71.00	85.70	15.9	1.3	13.2	65.10
2 3/4	69.85	90.00	98.00	49.20	74.60	88.90	15.9	1.3	13.2	65.10
2 7/8	73.03	95.00	104.00	52.40	77.80	95.25	15.9	1.3	13.2	68.30
3	76.20	99.00	104.00	52.40	81.00	98.43	15.9	1.3	13.2	68.30
3 1/8	79.38	104.00	109.00	55.50	80.10	101.60	19.8	1.3	15.4	74.90
3 1/4	82.55	109.00	114.00	55.50	87.30	104.78	19.8	1.3	15.4	74.90
3 3/8	85.73	109.00	114.00	55.50	90.50	107.95	19.8	1.3	15.4	74.90
3 1/2	88.90	114.00	119.00	55.50	93.60	111.13	19.8	1.3	15.4	74.90
3 5/8	92.08	119.00	124.00	58.70	96.80	114.30	19.8	1.3	15.4	78.50
3 3/4	95.25	119.00	124.00	58.70	100.00	117.48	19.8	1.3	15.4	78.50
3 7/4	98.43	124.00	129.00	61.90	103.10	120.65	19.8	1.3	15.4	81.70
4	101.60	124.00	129.00	61.90	106.30	123.83	19.8	1.3	15.4	81.70

Dimensions subject to changes or modifications.

DIMENSIONS CHART LRB01S

Dimensions in inches

Shaft (")	Rotary part			Stationary part						Total length l ₁
	mm	d ₃	d ₄	l ₃	d ₆	d ₇	l ₄	l ₅	l ₆	
3/8	9.52	22	27	25.4	16	24.6	8.7	1.3	6.2	34.1
1/2	12.70	26	31	25.4	19	27.8	8.7	1.3	6.2	34.1
5/8	15.88	32	37	25.4	22	30.9	10.3	1.3	9.0	35.7
3/4	19.05	36	41	25.4	25	34.1	10.3	1.3	9.0	35.7
7/8	22.20	39	44	25.4	28	37.3	10.3	1.3	9.0	35.7
1	25.40	42	47	25.4	32	40.5	10.3	1.3	9.0	35.7
1 1/8	28.60	46	51	33.3	36	47.6	12.0	1.3	9.2	45.5
1 1/4	31.75	49	54	33.3	39	50.8	12.0	1.3	9.2	45.5
1 3/8	34.92	54	59	33.3	42	53.9	12.0	1.3	9.2	45.5
1 1/2	38.10	59	64	33.3	45	57.1	12.0	1.3	9.2	45.5
1 5/8	41.27	61	66	33.3	48	60.3	12.0	1.3	9.2	45.5
1 3/4	44.45	64	69	40.5	52	63.5	12.0	1.3	9.2	52.5
1 7/8	47.62	66	71	40.5	55	66.7	12.0	1.3	9.2	52.5
2	50.80	69	74	40.5	58	69.8	13.5	1.3	10.7	54.0
2 1/8	53.97	78	83	41.0	62	73.1	13.5	1.3	10.7	54.5
2 1/4	57.15	80	85	41.0	65	76.2	13.5	1.3	10.7	54.5
2 3/8	60.32	83	88	41.0	68	79.4	13.5	1.3	10.7	54.5
2 1/2	63.50	85	90	41.0	71	82.5	13.5	1.3	10.7	54.5
2 5/8	66.68	90	95	49.0	78	92.1	15.9	1.3	13.2	64.9
2 3/4	69.85	95	100	49.0	81	95.2	15.9	1.3	13.2	64.9
2 7/8	73.03	99	104	49.0	84	98.4	15.9	1.3	13.2	64.9
3	76.20	99	104	49.0	88	101.6	15.9	1.3	13.2	64.9
3 1/8	79.38	104	109	56.0	94	111.1	20.0	1.3	17.2	76.0
3 1/4	82.55	109	114	56.0	97	114.3	20.0	1.3	17.2	76.0
3 3/8	85.73	109	114	56.0	100	117.5	20.0	1.3	17.2	76.0
3 1/2	88.90	114	119	56.0	103	120.6	20.0	1.3	17.2	76.0
3 5/8	92.08	119	124	59.0	106	123.8	20.0	1.3	17.2	79.0
3 3/4	95.25	119	124	59.0	109	127.0	20.0	1.3	17.2	79.0
3 7/4	98.43	124	129	62.0	113	130.2	20.0	1.3	17.2	82.0
4	101.60	124	129	62.0	116	133.3	20.0	1.3	17.2	82.0

Dimensions subject to changes or modifications.