

Design

A medium to heavy duty double acting seal, the Hallite 56 has shown itself over many years to be an effective and robust piston seal in a wide variety of applications. Designed for split pistons it offers the benefits in terms of sealing efficiency and low friction gained from rubber/fabric and a specific proportion of rubber in contact with the cylinder surface.

The centre of the seal is rubber which is bonded to two 'U' section bases of rubberised fabric, and is compressed by the housing to obtain an effective low pressure seal. When the pressure increases the rubber energises the 'U' section and deforms it to the housing, increasing the sealing area and improving the seal.

Rubberised fabric is used to protect the rubber because it has strength and durability which combines with its ability to retain lubricant, to help keep friction low and reduce wear.

The proportions of the range have been determined to give a satisfactory performance when used with the recommended operating conditions.

Many other sizes are available outside this range.

Features

- Well proven design
- Tolerant to contamination
- Wide range of non standard sizes

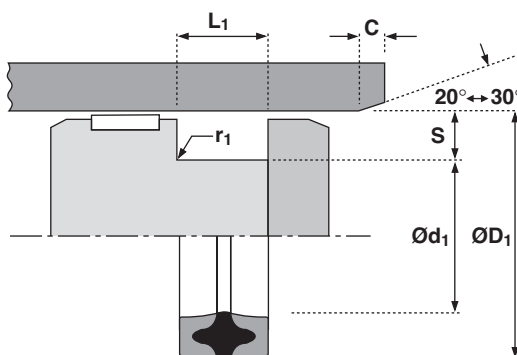

Technical details

Operating conditions

Maximum Speed	0.5 m/sec
Temperature Range	-30°C +100°C
Maximum Pressure	500 bar

Inch

Maximum Speed	1.5 ft/sec
Temperature Range	-22°F +212°F
Maximum Pressure	7500 p.s.i.

Maximum extrusion gap

Figures show the maximum permissible gap all on one side using minimum rod \varnothing and maximum clearance \varnothing . Refer to Housing Design section.

Pressure bar	160	250	400	500
Maximum Gap mm	0.35	0.3	0.2	0.1
Pressure p.s.i.	2400	3750	6000	7500
Maximum Gap in	0.016	0.012	0.008	0.004

Surface roughness

	μmRa	μmRt	μinCLA	μinRMS
Dynamic Sealing Face $\varnothing D_1$	0.1 < > 0.4	4 max	4 < > 16	5 < > 18
Static Sealing Face $\varnothing d_1$	1.6 max	10 max	63 max	70 max
Static Housing Faces L_1	3.2 max	16 max	125 max	140 max

Chamfers & Radii

	5.0	7.5	8.0	10.0	12.5
Groove Section $\leq S$ mm	5.0	7.5	8.0	10.0	12.5
Min Chamfer C mm	2.4	4.0	5.0	5.0	6.5
Max Fillet Rad r_1 mm	0.4	0.8	0.8	1.2	1.6
Groove Section $\leq S$ in	0.250	0.312	0.375	0.500	0.625
Min Chamfer C in	0.125	0.156	0.187	0.217	0.250
Max Fillet Rad r_1 in	0.016	0.016	0.032	0.032	0.047

Tolerances

	$\varnothing D_1$	$\varnothing d_1$	L_1
mm	H11	js11	+0.25 +0
in	H11	js11	+0.030 +0.020



piston seals

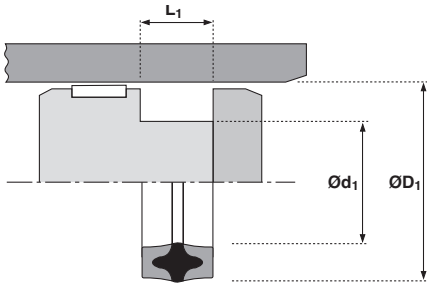

ØD ₁	TOL H11	Ød ₁	TOL js11	L ₁ +0.25 -0	PART No.
30	+0.13 +0.00	20	+0.07 -0.07	12.5	0200540
40	+0.16 +0.00	25	+0.07 -0.07	19.0	0472840
50	+0.16 +0.00	35	+0.08 -0.08	19.0	0474640
55	+0.19 +0.00	40	+0.08 -0.08	19.0	0475040
60	+0.19 +0.00	40	+0.08 -0.08	25.0	0282040
60	+0.19 +0.00	45	+0.08 -0.08	19.0	0979440
63	+0.19 +0.00	43	+0.08 -0.08	25.0	0646740
65	+0.19 +0.00	50	+0.08 -0.08	19.0	0383840
70	+0.19 +0.00	50	+0.08 -0.08	25.0	0294640
75	+0.19 +0.00	55	+0.10 -0.10	25.0	0818640
80	+0.19 +0.00	60	+0.10 -0.10	25.0	0294940
85	+0.22 +0.00	65	+0.10 -0.10	25.0	0388640
90	+0.22 +0.00	70	+0.10 -0.10	25.0	0296040
100	+0.22 +0.00	80	+0.10 -0.10	25.0	0295140
110	+0.22 +0.00	90	+0.11 -0.11	25.0	0712440
120	+0.22 +0.00	100	+0.11 -0.11	25.0	0296140
125	+0.25 +0.00	100	+0.11 -0.11	19.0	1007440
125	+0.25 +0.00	100	+0.11 -0.11	32.0	0418640
140	+0.25 +0.00	120	+0.11 -0.11	25.0	0250540
150	+0.25 +0.00	120	+0.11 -0.11	38.0	1289540

ØD ₁	TOL H11	Ød ₁	TOL js11	L ₁ +0.25 -0	PART No.
160	+0.25 +0.00	135	+0.13 -0.13	32.0	0080440
170	+0.25 +0.00	150	+0.13 -0.13	25.0	0303340
180	+0.25 +0.00	160	+0.13 -0.13	25.0	1283140
190	+0.29 +0.00	160	+0.13 -0.13	38.0	0838440
200	+0.29 +0.00	170	+0.13 -0.13	38.0	0087140
220	+0.29 +0.00	190	+0.15 -0.15	38.0	0087340
230	+0.29 +0.00	200	+0.15 -0.15	38.0	2010040
240	+0.29 +0.00	210	+0.15 -0.15	38.0	0094340
250	+0.29 +0.00	220	+0.15 -0.15	38.0	1056340
260	+0.32 +0.00	230	+0.15 -0.15	38.0	0094540
300	+0.32 +0.00	270	+0.16 -0.16	38.0	0094840
330	+0.36 +0.00	300	+0.16 -0.16	38.0	0095040
360	+0.36 +0.00	320	+0.18 -0.18	45.0	1054040
400	+0.36 +0.00	360	+0.18 -0.18	45.0	1054340
420	+0.40 +0.00	380	+0.20 -0.20	45.0	0095140
460	+0.40 +0.00	420	+0.20 -0.20	45.0	0095340
480	+0.40 +0.00	440	+0.20 -0.20	45.0	0095440
500	+0.40 +0.00	460	+0.20 -0.20	45.0	0134740
540	+0.44 +0.00	500	+0.20 -0.20	45.0	2018240
580	+0.44 +0.00	540	+0.22 -0.22	50.0	2020940

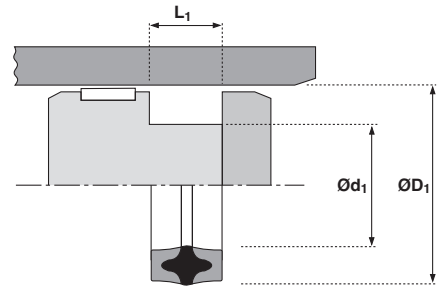

ØD ₁	TOL H11	Ød ₁	TOL js11	L ₁		PART No.
				+0.030	+0.020	
1.250	+0.006 +0.000	0.750	+0.003 -0.003	0.625		0403740
1.500	+0.006 +0.000	1.000	+0.003 -0.003	0.625		0422440
1.750	+0.006 +0.000	1.125	+0.003 -0.003	0.750		0778240
2.000	+0.007 +0.000	1.375	+0.003 -0.003	0.750		0778440
2.250	+0.007 +0.000	1.625	+0.003 -0.003	0.750		1432640
2.375	+0.007 +0.000	1.750	+0.003 -0.003	0.750		0939840
2.500	+0.007 +0.000	1.875	+0.003 -0.003	0.750		0867240
2.750	+0.007 +0.000	2.000	+0.004 -0.004	0.937		1369140
2.875	+0.007 +0.000	2.125	+0.004 -0.004	0.937		0779640
3.000	+0.007 +0.000	2.250	+0.004 -0.004	0.937		1098440
3.250	+0.009 +0.000	2.500	+0.004 -0.004	0.937		0782440
3.500	+0.009 +0.000	2.750	+0.004 -0.004	0.937		0437840
3.750	+0.009 +0.000	3.000	+0.004 -0.004	0.937		0410540
4.000	+0.009 +0.000	3.250	+0.004 -0.004	0.719		6504740
4.000	+0.009 +0.000	3.250	+0.004 -0.004	0.937		1407740
4.250	+0.009 +0.000	3.500	+0.004 -0.004	0.937		1128840
4.500	+0.009 +0.000	3.500	+0.004 -0.004	1.250		0448840
4.625	+0.009 +0.000	3.625	+0.004 -0.004	1.250		0449040
4.750	+0.010 +0.000	3.750	+0.004 -0.004	1.250		1007040
5.000	+0.010 +0.000	4.000	+0.004 -0.004	1.250		0443040
5.250	+0.010 +0.000	4.250	+0.004 -0.004	1.250		0892240
5.500	+0.010 +0.000	4.500	+0.004 -0.004	1.250		0133240
6.000	+0.010 +0.000	5.000	+0.005 -0.005	1.250		1367040
6.500	+0.010 +0.000	5.500	+0.005 -0.005	1.250		1164140

ØD ₁	TOL H11	Ød ₁	TOL js11	L ₁		PART No.
				+0.030	+0.020	
7.000	+0.010 +0.000	6.000	+0.005 -0.005	1.250		1188840
7.250	+0.011 +0.000	6.000	+0.005 -0.005	1.625		0424140
7.500	+0.011 +0.000	6.250	+0.005 -0.005	1.625		1255240
8.000	+0.011 +0.000	6.750	+0.005 -0.005	1.625		0426540
8.000	+0.011 +0.000	7.000	+0.005 -0.005	1.000		0224340
8.250	+0.011 +0.000	7.000	+0.005 -0.005	1.625		1219240
8.500	+0.011 +0.000	7.250	+0.005 -0.005	1.625		1286440
9.000	+0.011 +0.000	7.750	+0.006 -0.006	1.625		1266640
9.250	+0.011 +0.000	8.000	+0.006 -0.006	1.625		0455740
9.500	+0.011 +0.000	8.250	+0.006 -0.006	1.625		1332240
9.750	+0.011 +0.000	8.500	+0.006 -0.006	1.625		1332340
10.000	+0.013 +0.000	8.750	+0.006 -0.006	1.625		0436140
10.500	+0.013 +0.000	9.250	+0.006 -0.006	1.625		1331940
10.750	+0.013 +0.000	9.500	+0.006 -0.006	1.625		1320440
11.000	+0.013 +0.000	9.750	+0.006 -0.006	1.625		0433940
11.500	+0.013 +0.000	10.250	+0.006 -0.006	1.625		1331640
12.000	+0.013 +0.000	10.750	+0.006 -0.006	1.625		1331440
13.250	+0.013 +0.000	12.000	+0.006 -0.006	1.625		1329140
14.500	+0.013 +0.000	13.000	+0.006 -0.006	1.500		0270940
15.000	+0.013 +0.000	13.750	+0.007 -0.007	1.500		0787040
16.000	+0.016 +0.000	14.750	+0.007 -0.007	1.800		2117440
19.500	+0.016 +0.000	18.000	+0.008 -0.008	2.500		2108240
20.000	+0.017 +0.000	18.500	+0.009 -0.009	1.750		2111240

