

SRS

ROD BUFFER SEAL

TECHNICAL DETAILS

The Hallite SRS is a single-acting, low-friction rod buffer seal, designed to be utilized in conjunction with a primary pressure seal. The buffer is designed from proprietary Armorlene® material face ring paired with a specially profiled energizer. The Armorlene® face ring offers low friction and the elimination of stick-slip. High-performance Armorlene® materials, like HLX, provide outstanding wear and extrusion-resistance properties as well as large range of temperature and media compatibility.

The SRS is a pressure buffer seal that protects the primary rod seal from high-frequency pressure spikes in a system. The design allows oil to pass through to the rod seal while holding back pressure spikes. The Hallite SRS also allows pressure to pass back into the system, preventing a pressure trap situation between the rod seal and the buffer seal. The SRS is an excellent addition to demanding sealing applications, offering extended sealing system life and performance.



FEATURES

- Self-relieving design prevents pressure trapping
- Low breakout friction and elimination of stick-slip action
- Excellent in high-speed applications
- Wide range of materials for both face ring and energizer available for special applications
- High service temperature, long wear, and high extrusion resistance

Part Number Structure

SRSMR00700NHLX _

SRS	M	R	00700	N	HLX	_
PROFILE DESIGNATION	UNIT OF MEASUREMENT M = Metric E = Inch	APPLICATION Refer to <i>Installation Recommendations</i> and use designator for desired application	ROD DIAMETER Metric = mm X 10 Inch = inches X 1000	ENERGIZER MATERIAL Refer to <i>Energizer Table</i> for desired energizer material	PTFE MATERIAL Refer to <i>Material Table</i> for desired PTFE (face) material	SPECIAL FEATURE Blank = Std profile



OPERATING CONDITIONS

	metric	inch
Maximum Speed	Up to 4.0m/sec	Up to 12.0ft/sec
Temperature Range*	-45 to 200°C	-49 to 392°F
Maximum Dynamic Pressure**	400 bar	5800 psi

*Dependent upon energizer used (NBR, FKM, etc.). **For pressures above 400 bar, contact Hallite Engineering.

NOTE

Data given are maximum values and can apply depending on specific application. Maximum ratings of temperature, pressure, or operating speeds are dependent on fluid medium, surface, gap value, and other variables such as dynamic or static service. Maximum values are not intended for use together at the same time, e.g. max temperature and max pressure. Please contact your Hallite technical representative for application support.

SURFACE FINISH RECOMMENDATIONS

SURFACE ROUGHNESS	metric			inch			RMR*
	μMRA	μMRZ	μMRT	μINRA	μINRZ	μINRT	
Dynamic Sealing Face Ød₁	0.05 - 0.2	1.3 max	2 max	2 - 8	52 max	78 max	60% - 90%
Static Sealing Face ØD₁	1.6 max	7 max	10 max	63 max	276 max	394 max	
Static Housing Faces L₁	3.2 max	10 max	16 max	125 max	394 max	630 max	

*RMR is measured at a depth of 25% of the Rz value based upon a reference level (zero line) at 5% material/bearing area.

ENERGIZER TABLE*

ENERGIZER MATERIAL (SHORE A)	ENERGIZER TYPE	ENERGIZER DESIGNATION	ENERGIZER OPERATING TEMPERATURE °C
NBR - 85A	Square/Profile	N	-30 to 100°C
HNBR - 85A	Square/Profile	H	-20 to 150°C
FKM - 82A	Square/Profile	F	-10 to 200°C
NBR - 80A Low temp.	Square/Profile	B	-45 to 80°C

*Other energizer materials are available. Please contact your local Hallite sales office for further information.

MATERIALS

MATERIAL FEATURES AND APPLICATIONS	FILLER	MATERIAL DESIGNATOR	COLOR	TEMPERATURE RANGE°C	TEMPERATURE RANGE°F	MAXIMUM DYNAMIC PRESSURE - BAR	MAXIMUM DYNAMIC PRESSURE - PSI
ARMORLENE® HLX <ul style="list-style-type: none"> • Standard material for hydraulic applications • High compressive strength • Excellent extrusion resistance • Extended wear resistance 	Special Bronze Compound	HLX	Gold	-73 to 288°C	-100 to 550°F	500 bar	7250 psi
ARMORLENE® HLA <ul style="list-style-type: none"> • Excellent in all hydraulic fluids • Excellent wear resistance • Excellent low-friction properties • Good extrusion resistance 	Special Mineral Compound	HLA	Gray	-73 to 260°C	-100 to 500°F	500 bar	7250 psi
ARMORLENE® HCF <ul style="list-style-type: none"> • Excellent in lubricating and non-lubricating hydraulic fluids (includes water) w/o zinc content • Not recommended for gas sealing applications • Not recommended for electrical conductive fluids 	Carbon Fiber Filled	HCF	Gray/Black	-73 to 260°C	-100 to 500°F	250 bar	3625 psi
ARMORLENE® 713 <ul style="list-style-type: none"> • High compressive strength • Excellent extrusion resistance • Excellent wear properties 	60% Bronze Content	713	Bronze	-73 to 288°C	-100 to 550°F	500 bar	7250 psi

For other material options consult the Master Materials Index at the front of the catalog. If you do not find the material that you require, please contact your local Hallite sales office.



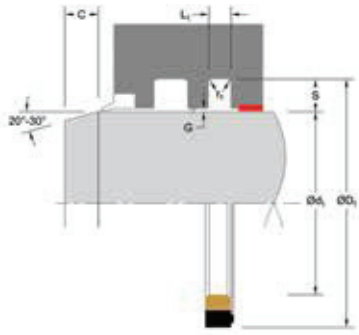

Applications with maximum radial clearance that are using nylon, phenolic, or PTFE bearings must ensure proper clearance in accordance with the bearing recommendations to avoid metal-to-metal contact. Please refer to Hallite Type 87, Type 506, and Type 533 Specification Sheets for this information.

INSTALLATION RECOMMENDATIONS

metric									
ROD DIAMETER $\varnothing d_1$ f8/h9		GROOVE DIAMETER	GROOVE WIDTH	RADIUS	CHAMFER	GROOVE SECTION	RADIAL CLEARANCE G_{max}^*		
DIAMETER RANGE		$\varnothing D_1$ H9	$L_1 + 0.2$	r_1	C	S	Up to 100 bar	Up to 200 bar	Up to 400 bar
Standard Duty Application - R	Light Duty Application - L								
40.0 - 199.9	200.0 - 255.9	$d_1 + 15.1$	6.3	0.4	2.0	7.55	0.50	0.30	0.20

At pressure >400 bar use diameter tolerance f8/h8.

*Radial Clearance G_{max} = maximum permissible gap all on one side using min. rod diameter and max. clearance diameter.

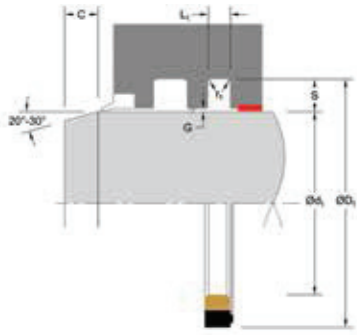

SRS

ROD BUFFER SEAL

PART NUMBER RANGE (METRIC)*

metric			PART NUMBER
Ød ₁	ØD ₁	L ₁	
Tol. f8/h9	Tol. H9	Tol. +0.2 - 0	
40.0	55.1	6.3	SRSMR00400****
45.0	60.1	6.3	SRSMR00450****
50.0	65.1	6.3	SRSMR00500****
55.0	70.1	6.3	SRSMR00550****
60.0	75.1	6.3	SRSMR00600****
65.0	80.1	6.3	SRSMR00650****
70.0	85.1	6.3	SRSMR00700****
75.0	90.1	6.3	SRSMR00750****
80.0	95.1	6.3	SRSMR00800****
85.0	100.1	6.3	SRSMR00850****
90.0	105.1	6.3	SRSMR00900****
95.0	110.1	6.3	SRSMR00950****
100.0	115.1	6.3	SRSMR01000****
105.0	120.1	6.3	SRSMR01050****
110.0	125.1	6.3	SRSMR01100****
115.0	130.1	6.3	SRSMR01150****
120.0	135.1	6.3	SRSMR01200****
125.0	140.1	6.3	SRSMR01250****
130.0	145.1	6.3	SRSMR01300****
135.0	150.1	6.3	SRSMR01350****
140.0	155.1	6.3	SRSMR01400****
145.0	160.1	6.3	SRSMR01450****
150.0	165.1	6.3	SRSMR01500****
155.0	170.1	6.3	SRSMR01550****
160.0	175.1	6.3	SRSMR01600****
165.0	180.1	6.3	SRSMR01650****
170.0	185.1	6.3	SRSMR01700****
175.0	190.1	6.3	SRSMR01750****

metric			PART NUMBER
Ød ₁	ØD ₁	L ₁	
Tol. f8/h9	Tol. H9	Tol. +0.2 - 0	
180.0	195.1	6.3	SRSMR01800****
185.0	200.1	6.3	SRSMR01850****
190.0	205.1	6.3	SRSMR01900****
195.0	210.1	6.3	SRSMR01950****
200.0	215.1	6.3	SRSML02000****
205.0	220.1	6.3	SRSML02050****
210.0	225.1	6.3	SRSML02100****
215.0	230.1	6.3	SRSML02150****
220.0	235.1	6.3	SRSML02200****
225.0	240.1	6.3	SRSML02250****
230.0	245.1	6.3	SRSML02300****
235.0	250.1	6.3	SRSML02350****
240.0	255.1	6.3	SRSML02400****
245.0	260.1	6.3	SRSML02450****
250.0	265.1	6.3	SRSML02500****

*Please contact Hallite for custom sizes, material selection, or seal design.

