



## CHARACTERISTICS:

- Balanced.
- Welded metal bellows.
- Not dependent on the rotation direction.

## OPERATING LIMITS:

$$d_1 = 24 \div 95 \text{ mm} \quad p = 20 \text{ kg/cm}^2$$

$$v = 25 \text{ m/s} \quad t = -40 \div +200^\circ\text{C} (*)$$

(\*) The temperature resistance depends on the material of the secondary seals used.

The operating limits are defined by the PV factor which is determined for the sealing system characteristics and those of the application.

## DESCRIPTION:

Single cartridge in which the rotating part has a metal bellows. Adequate for applications with extremely viscous, sticky, particle-laden fluids.

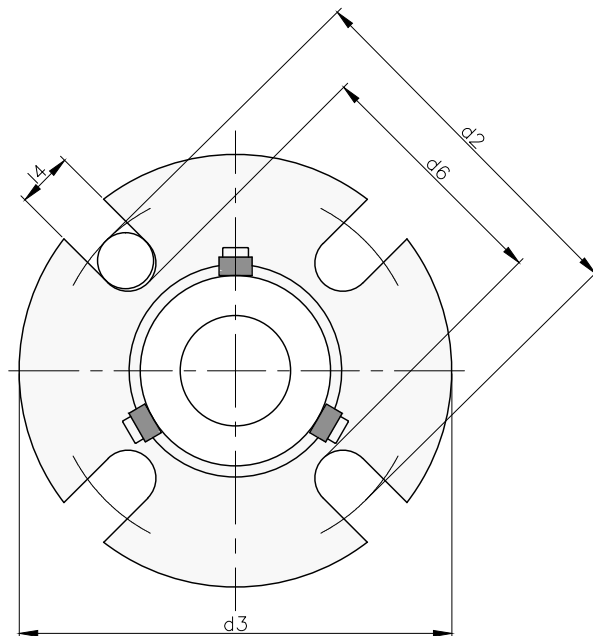

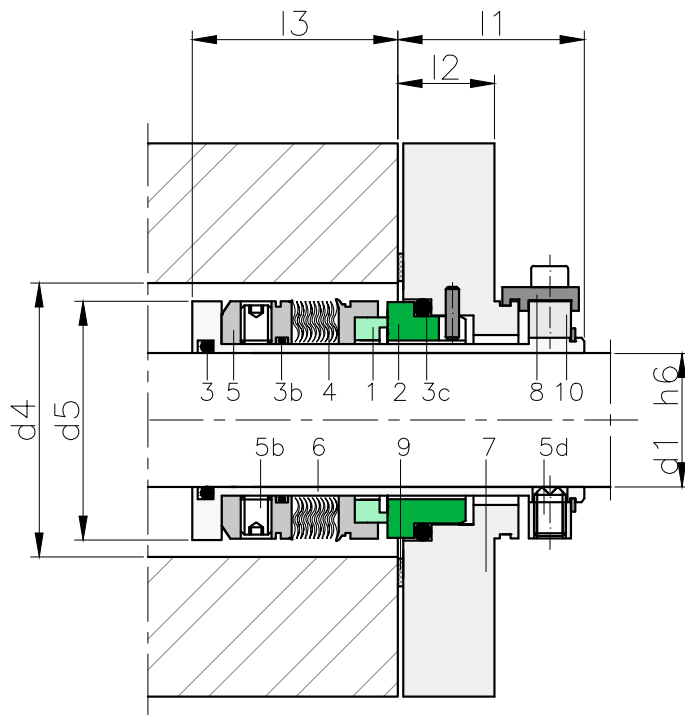

## COMPONENTS:

- 1 Rotating contact surface
- 2 Stationary contact surface
- 3 O-rings
- 4 Metal bellows
- 5 Metal frame
- 5b Set screws
- 6 Sleeve
- 7 Flange
- 8 Setting clips
- 9 Flat gasket
- 10 Drive ring

## DIMENSIONS CHART

Dimensions in mm

Shaft											
mm	d <sub>2</sub> min.	d <sub>2</sub> max.	d <sub>3</sub>	d <sub>4</sub> min.	d <sub>4</sub> max.	d <sub>5</sub>	d <sub>6</sub>	l <sub>1</sub>	l <sub>2</sub>	l <sub>3</sub>	l <sub>4</sub>
24	72	93	105	44	52	43	60	32	21	41	12
25	72	93	105	44	52	43	60	32	21	41	12
28	72	93	105	49	52	47	60	32	21	41	12
30	76	98	110	49	56	48	64	32	21	41	12
32	77	98	110	51	57	50	65	32	21	41	12
33	81.5	103	115	57	61.5	55	69.5	32	21	43.5	12
35	81.5	103	115	57	61.5	55	69.5	32	21	43.5	12
38	86	108	120	62	66	60	74	32	21	42	12
40	88	108	120	62	68	60	76	32	21	42	12
43	90.5	123	135	67	70.5	65	78.5	32	21	42	12
45	93	123	135	67	73	65	81	32	21	42	12
48	98	123	135	74	78	70	86	32	21	45.5	12
50	100	123	135	74	78	70	88	32	21	45.5	12
55	111	134	150	82	85	81	95	32	21	50.5	16
60	121	130	150	87	91	86	101	32	21	50.5	20
65	128.5	140	160	93	98.5	91	108.5	32	21	57	20
70	138	155	175	100	108	99	118	32	21	57	20
75	148	170	190	105	118	104	128	32	21	57	20
80	154	170	190	111	124	109	134	32	21	57	20
85	158	170	190	116	128	114	138	32	21	62	20
90	165	195	215	121	135	119	145	32	21	63	20
95	168	195	215	126	138	124	148	32	21	63	20

Dimensions subject to changes or modifications.