

LRB02

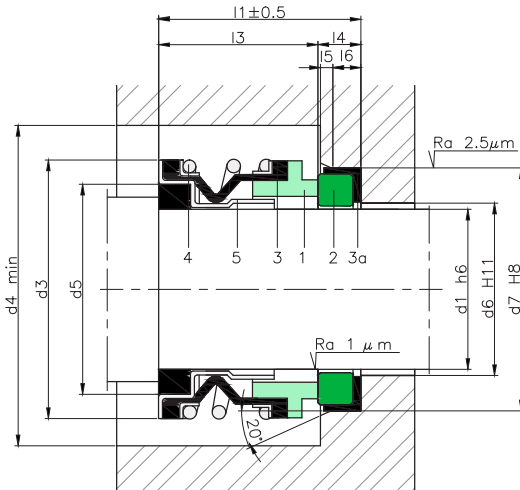

COMPONENTS:

- 1 Rotating contact surface
- 2 Stationary contact surface
- 3 Bellows
- 3a Elastomeric cup
- 4 Spring
- 5 Metal frame



SECTORS:



CHARACTERISTICS:

- Unbalanced.
- Not dependent on the rotation direction.
- Single cylindrical spring.

OPERATING LIMITS:

$d_1 = 9.52 \div 25.40 \text{ mm}$      $p = 7 \text{ kg/cm}^2$

$v = 10 \text{ m/s}$                        $t = -15 \div +200^\circ\text{C} (*)$

(\*) The temperature resistance depends on the material of the secondary seals used.

The operating limits are defined by the PV factor which is determined for the sealing system characteristics and those of the application.

DESCRIPTION:

Seal with a compact design for applications with low demands that require small diameters and often used for water pumps.

DIMENSIONS CHART

Dimensions in inches

Shaft (")	mm	Rotary part				Stationary part					Total length $l_1$
		$d_3$	$d_4$	$d_5$	$l_3$	$d_6$	$d_7$	$l_4$	$l_5$	$l_6$	
3/8	9.52	23.80	28.80	17.46	16.00	14.3	22.22	6.2	1.3	5.1	22.2
1/2	12.70	26.97	31.97	20.63	18.30	17.5	25.40	8.0	1.3	5.1	26.3
5/8	15.88	30.94	35.94	23.81	18.70	20.6	31.75	10.3	1.3	7.5	29.0
3/4	19.05	34.11	39.11	26.98	18.70	23.8	34.93	10.3	1.3	7.5	29.0
1	25.40	42.85	47.85	33.33	20.60	30.2	41.28	11.0	1.3	7.5	31.6

Dimensions subject to changes or modifications.