

LMB85

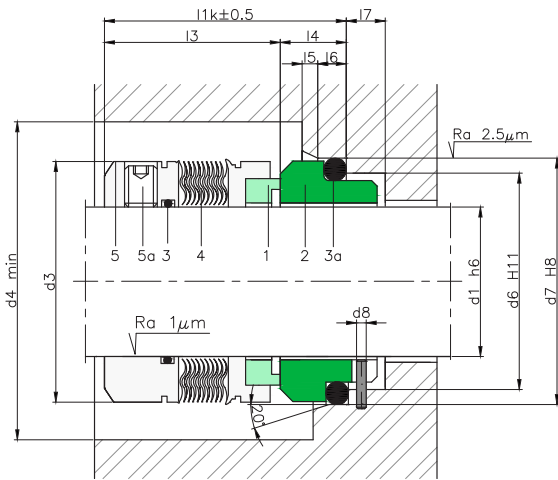

COMPONENTS:

- 1 Rotating contact surface
- 2 Stationary contact surface
- 3 O-rings
- 3a O-rings
- 4 Metal bellows
- 5 Metal frame
- 5a Set screws



SECTORS:



CHARACTERISTICS:

- **Balanced.**
- **Welded metal bellows.**
- **Not dependent on the rotation direction.**

OPERATING LIMITS:

$d_1 = 16 \div 100 \text{ mm}$ $p = 20 \text{ kg/cm}^2$
 $v = 25 \text{ m/s}$ $t = -40 \div +200^\circ\text{C}$
 -40 ÷ +200 °C (up to 400° C with a special design) (*)

(*) The temperature resistance depends on the material of the secondary seals used.

The operating limits are defined by the PV factor which is determined for the sealing system characteristics and those of the application.

DESCRIPTION:

Internally balanced, with no need for a stepped shaft (models LWS10B, LMS20B). The O-ring resting on the shaft does not cause wear as there is no axial movement. Appropriate for applications with sticky or high viscosity fluids as its open leaf design generates a self-cleaning effect. In addition it is suitable for application at moderate pressures and high temperatures (for up to 400° C please enquire) and very aggressive fluids in chemical and mechanical terms. Very often used in compressors.

DIMENSIONS CHART

Dimensions in mm

Shaft mm	Rotary part		
	d ₃	d ₄	l ₃
16	30	34	32,5
18	32	36	30,5
20	33,5	37,5	30,5
22	36,5	40,5	30,5
24	39	43	28,5
25	39,6	43	28,5
28	42,8	46,8	31
30	45	49	31
32	46	50	31
33	48	52	31
35	49,2	63,2	31
38	52,3	56,3	31
40	55,5	59,5	31
43	57,5	61,5	31
45	58,7	62,7	31
48	61,9	65,9	31
50	65	69	32,5
53	68,2	72,2	32,5
55	70	74	32,5
58	71,7	75,7	37,5
60	74,6	78,6	37,5
63	79	83	37,5
65	84,1	88,1	37,5
68	87,3	91,3	34,5
70	87,3	91,3	42
75	95	99	42
80	98,4	102,4	41,8
85	104,7	108,7	41,8
90	111	115	46,8
95	114	118	47,8
100	117,4	121,4	47,8

Dimensions in inches

Shaft (")	mm	Rotary part			Stationary part			Total length
		d ₃	d ₄	l ₃	d ₆	d ₇	l ₄	l ₁
0,750	19,05	34	38	30,5	29,5	35	11,5	42
0,875	22,23	39	43	28,5	33,5	39	11,5	40
1,000	25,40	39,6	43,6	28,5	34,5	40	11,5	40
1,125	28,58	42,8	46,8	31	37,5	43	11,5	42,5
1,250	31,75	46	50	31	42,5	48	11,5	42,5
1,375	34,93	49,2	53,2	31	44,5	50	11,5	42,5
1,500	38,10	52,5	56,5	31	49,5	56	14	45
1,625	41,28	55,5	59,5	31	54,5	61	14	45
1,750	44,45	59,5	63,5	31	56,5	63	14	45
1,875	47,63	62,5	66,5	31	59,5	66	14	45
2,000	50,80	65	69	32,5	62,5	70	15	47,5
2,125	53,98	68,2	72,2	32,5	67,5	75	15	47,5
2,250	57,15	71,7	75,7	37,5	70,5	78	15	52,5
2,375	60,33	75	79	37,5	72,5	80	15	52,5
2,500	63,50	79	83	37,5	75,5	83	15	52,5
2,625	66,68	84,1	88,1	34,5	81,5	90	18	52,5
2,750	69,85	87,3	91,3	42	83,5	92	18	60
2,875	73,03	92	96	42	88,5	97	18	60
3,000	76,20	95	99	42	88,5	97	18	60
3,125	79,38	98,4	102,4	41,8	95,5	105	18,2	60
3,250	82,55	101,6	105,6	41,8	100,5	110	18,2	60
3,375	85,73	104,7	108,7	41,8	100,5	110	18,2	60
3,500	88,90	108	112	46,8	105,5	115	18,2	65
3,625	92,08	111	115	46,8	105,5	115	18,2	65
3,750	95,25	114	118	47,8	110,5	120	17,2	65
3,875	98,43	117,5	121,5	47,8	115,5	125	17,2	65
4,000	101,60	119	123	47,8	115,5	125	17,2	65

Dimensions subject to changes or modifications.