

# FN / LS15 and FN.NU / LS15DIN

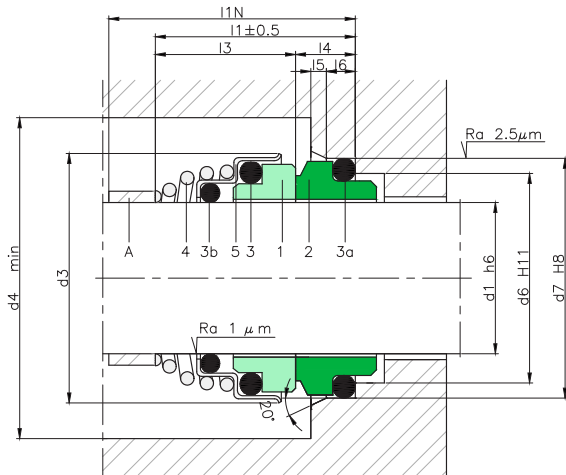

**COMPONENTS:**

- 1 Rotating contact surface
- 2 Stationary contact surface
- 3 O-rings
- 3a O-rings
- 3b O-rings
- 4 Spring
- 5 Metal frame
- A Spacer not provided with the seal



**SECTORS:**



**CHARACTERISTICS:**

- Unbalanced.
- Single conical spring.
- Dependent on the rotation direction.

**OPERATING LIMITS:**

$d_1 = 10 \div 40 \text{ mm}$        $p = 10 \text{ kg/cm}^2$   
 $v = 20 \text{ m/s}$                $t = -20 \div +180^\circ\text{C} (*)$

(\*) The temperature resistance depends on the material of the secondary seals used.

The operating limits are defined by the PV factor which is determined for the sealing system characteristics and those of the application.

**DESCRIPTION:**

An all-purpose mechanical seal.  
 A single seal with a versatile design that can be used in applications with low demands: for pumping industrial wastewater and for household use.  
 Seal compliant with standard EN 12756 (NU).

**DIMENSIONS CHART FN / LS15**

Dimensions in mm

Shaft mm	Rotary part			Stationary part					Total length	
	$d_3$	$d_4$	$l_3$	$d_6$	$d_7$	$l_4$	$l_5$	$l_6$	$l_{11}$	$l_1$
10	19.5	22	15	14.0	18.1	5.5	1.2	3		20.5
11	22.0	25	18	16.5	20.6	5.5	1.2	3		23.5
12	22.8	25	18	16.5	20.6	5.5	1.2	3		23.5
13	25.0	28	22	19.0	23.1	6.0	1.2	3		28.0
14	25.0	28	22	19.0	23.1	6.0	1.2	3		28.0
15	28.6	32	22	21.0	26.9	7.0	1.5	4		29.0
16	28.6	32	23	21.0	26.9	7.0	1.5	4		30.0
17	28.6	32	23	21.0	26.9	7.0	1.5	4		30.0
18	32.7	36	24	25.0	30.9	8.0	1.5	4		32.0
19	32.7	36	25	25.0	30.9	8.0	1.5	4		33.0
20	32.7	36	25	25.0	30.9	8.0	1.5	4		33.0
21	37.4	42	25	30.0	35.4	8.0	1.5	4		33.0
22	37.4	42	25	30.0	35.4	8.0	2.0	4		33.0
24	37.4	42	27	30.0	35.4	8.0	2.0	4		35.0
25	40.0	45	27	33.0	38.2	8.5	2.0	4		35.5
28	45.5	51	29	38.0	43.3	9.0	2.0	4		38.0
30	45.5	51	30	38.0	43.3	9.0	2.0	4		39.0
32	45.5	51	30	38.0	43.3	9.0	2.0	4		39.0
35	50.0	55	39	45.0	53.5	11.5	2.0	6		50.5
38	56.0	68	39	52.0	60.5	11.5	2.0	6		50.5
40	58.0	68	39	52.0	60.5	11.5	2.0	6		50.5

Dimensions subject to changes or modifications.

**DIMENSIONS CHART FN.NU / LS15DIN**

Dimensions in mm

Shaft mm	Rotary part			Stationary part					Total length	
	$d_3$	$d_4$	$l_3$	$d_6$	$d_7$	$l_4$	$l_5$	$l_6$	$l_{11}$	$l_1$
10	20.0	22	15	17	21	7	1	4	40	22
12	22.0	25	18	19	23	7	1	4	40	25
14	24.0	28	22	21	25	7	1	4	40	29
16	26.0	32	23	23	27	7	1	4	40	30
18	32.0	36	24	27	33	10	4	9	45	34
20	33.0	36	25	29	35	10	5	9	45	35
22	36.0	42	25	31	37	10	5	9	45	35
24	37.4	42	27	33	39	10	5	9	50	37
25	38.0	45	27	34	40	10	5	9	50	37
28	42.0	51	29	37	43	10	5	9	50	39
30	44.0	51	30	39	45	10	5	9	50	40
32	45.5	51	30	42	48	10	5	9	55	40
33	46.5	51	39	42	48	10	5	9	55	49
35	49.0	55	39	44	50	10	5	9	55	49
38	56.0	68	42	49	56	13	5	9	55	55
40	58.0	68	42	51	58	13	5	9	55	55