

FH / FHC



COMPONENTS:

- 1 Rotating contact surface
- 2 Stationary contact surface
- 3 O-rings
- 3a O-rings
- 3b O-rings
- 3T PTFE wedge
- 3Ta PTFE gasket
- 4 Spring
- 5 Metal frame

SECTORS:



CHARACTERISTICS:

- Unbalanced.
- Single conical spring.
- Dependent on the rotation direction.
- Exchangeable contact surfaces.

OPERATING LIMITS:

- $d_1 = 10 \div 100 \text{ mm}$      $p = 10 \text{ kg/cm}^2$
- $v = 20 \text{ m/s}$              $t = -20 \div +200^\circ\text{C}$  (\*)

(\*) The temperature resistance depends on the material of the secondary seals used.

The operating limits are defined by the PV factor which is determined for the sealing system characteristics and those of the application.

DESCRIPTION:

A general-purpose single, robust seal in which the contact surfaces can be exchanged with each other. It can be used in industrial applications for clean fluids with low viscosities or with a low content of suspended solids that tend to produced sediments or adhere to the seal.

Types:

FH6: secondary seals made of PTFE.

FHC: same structure as FH but the length is I3C.

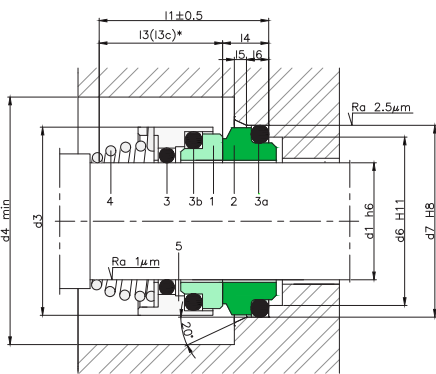

TYPE FH

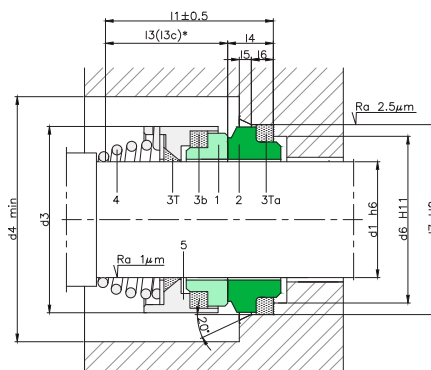

TYPE FH PTFE

DIMENSIONS CHART

Dimensions in mm

Shaft mm	Rotary part				Stationary part					Total length l <sub>1</sub>
	d <sub>3</sub>	d <sub>4</sub>	l <sub>3</sub>	l <sub>3c</sub> *	d <sub>6</sub>	d <sub>7</sub>	l <sub>4</sub>	l <sub>5</sub>	l <sub>6</sub>	
10	20	22	20	15	14.0	18.1	5.5	1.2	3	25.5
12	22	25	22	18	16.5	20.6	5.5	1.2	3	27.5
14	25	28	27	22	19.0	23.1	6.0	1.2	3	33.0
15	29	32	27	22	21.0	26.9	7.0	1.5	4	34.0
16	29	32	28	23	21.0	26.9	7.0	1.5	4	35.0
18	33	36	30	24	25.0	30.9	8.0	1.5	4	38.0
20	33	36	30	25	25.0	30.9	8.0	1.5	4	38.0
22	38	41	30	25	30.0	35.4	8.0	2.0	4	38.0
24	38	41	32	27	30.0	35.4	8.0	2.0	4	40.0
25	40	45	33	27	33.0	38.2	8.5	2.0	4	41.5
26	40	45	33	27	33.0	38.2	8.5	2.0	4	41.5
28	46	50	36	29	38.0	43.3	9.0	2.0	4	45.0
30	46	50	37	30	38.0	43.3	9.0	2.0	4	46.0
32	46	50	37	30	38.0	43.3	9.0	2.0	4	46.0
34	56	62	48	39	45.0	53.5	11.5	2.0	6	59.5
35	56	62	48	39	45.0	53.5	11.5	2.0	6	59.5
36	56	62	48	39	45.0	53.5	11.5	2.0	6	59.5
38	63	70	48	39	52.0	60.5	11.5	2.0	6	59.5
40	63	70	48	39	52.0	60.5	11.5	2.0	6	59.5
42	63	70	48	39	52.0	60.5	11.5	2.0	6	59.5
43	63	70	48	41	52.0	60.5	11.5	2.0	6	59.5
45	69	75	51	41	57.0	65.5	11.5	2.0	6	62.5
48	69	75	51	41	57.0	65.5	11.5	2.0	6	62.5
50	76	83	55	45	64.0	72.5	11.5	2.0	6	66.5
55	76	83	57	47	64.0	72.5	11.5	2.0	6	68.5
60	84	90	61	49	72.0	79.3	11.5	2.0	6	72.5
65	89	96	63	51	77.0	84.5	11.5	2.0	6	74.5
70	94	101	63	51	82.0	89.5	11.5	2.0	6	74.5
75	100	106	68	57	87.0	94.5	11.5	2.0	6	79.5
80	105	111	70	59	92.0	99.5	11.5	2.0	6	81.5
85	115	125	72	59	98.0	105.5	13.5	2.5	6	85.5
90	120	132	75	62	105	111.5	13.5	2.5	6	88.5
95	126	137	75	62	110	116.5	13.5	2.5	6	88.5
100	130	143	85	75	114	119.5	13.5	2.5	6	98.5

Dimensions subject to changes or modifications.